

CANDIDATE  
NAME

--

CENTRE  
NUMBER

--	--	--	--	--

CANDIDATE  
NUMBER

--	--	--	--

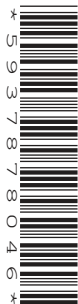

**CAMBRIDGE INTERNATIONAL MATHEMATICS**

**0607/43**

Paper 4 (Extended)

**October/November 2019**

**2 hours 15 minutes**

Candidates answer on the Question Paper.

Additional Materials:      Geometrical Instruments  
   Graphics Calculator

**READ THESE INSTRUCTIONS FIRST**

Write your centre number, candidate number and name on all the work you hand in.

Write in dark blue or black pen.

Do not use staples, paper clips, glue or correction fluid.

You may use an HB pencil for any diagrams or graphs.

**DO NOT WRITE IN ANY BARCODES.**

Answer **all** the questions.

Unless instructed otherwise, give your answers exactly or correct to three significant figures as appropriate.

Answers in degrees should be given to one decimal place.

For  $\pi$ , use your calculator value.

You must show all the relevant working to gain full marks and you will be given marks for correct methods, including sketches, even if your answer is incorrect.

The number of marks is given in brackets [ ] at the end of each question or part question.

The total number of marks for this paper is 120.

This document consists of **20** printed pages.

## Formula List

For the equation  $ax^2 + bx + c = 0$   $x = \frac{-b \pm \sqrt{b^2 - 4ac}}{2a}$

Curved surface area,  $A$ , of cylinder of radius  $r$ , height  $h$ .  $A = 2\pi rh$

Curved surface area,  $A$ , of cone of radius  $r$ , sloping edge  $l$ .  $A = \pi rl$

Curved surface area,  $A$ , of sphere of radius  $r$ .  $A = 4\pi r^2$

Volume,  $V$ , of pyramid, base area  $A$ , height  $h$ .  $V = \frac{1}{3}Ah$

Volume,  $V$ , of cylinder of radius  $r$ , height  $h$ .  $V = \pi r^2 h$

Volume,  $V$ , of cone of radius  $r$ , height  $h$ .  $V = \frac{1}{3}\pi r^2 h$

Volume,  $V$ , of sphere of radius  $r$ .  $V = \frac{4}{3}\pi r^3$

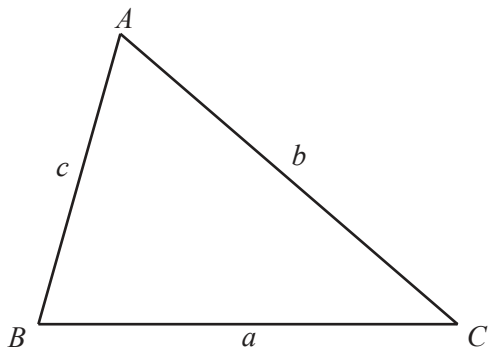

$$\frac{a}{\sin A} = \frac{b}{\sin B} = \frac{c}{\sin C}$$

$$a^2 = b^2 + c^2 - 2bc \cos A$$

$$\text{Area} = \frac{1}{2}bc \sin A$$

Answer **all** the questions.

- 1 (a) Aisha invests \$12 000 at a compound interest rate of 3.5% per year.

Calculate the value of her investment at the end of 4 years.

\$..... [3]

- (b) 2 years ago, Byron invested \$ $P$  at a compound interest rate of 3% per year.  
The value of his investment is now \$10 078.55 .

Calculate the value of  $P$ .

$P =$  ..... [3]

- (c) 5 years ago Cheng invested \$ $Q$  at a **simple** interest rate of 4% per year.  
The value of his investment is now \$20 400.

Calculate the value of  $Q$ .

$Q =$  ..... [3]

2 The table shows the number of goals scored in 100 matches.

Number of goals	0	1	2	3	4	5	6	7
Frequency	17	23	20	18	11	6	4	1

Find

(a) the mode,

..... [1]

(b) the range,

..... [1]

(c) the median,

..... [1]

(d) the inter-quartile range,

..... [2]

(e) the mean.

..... [2]

3

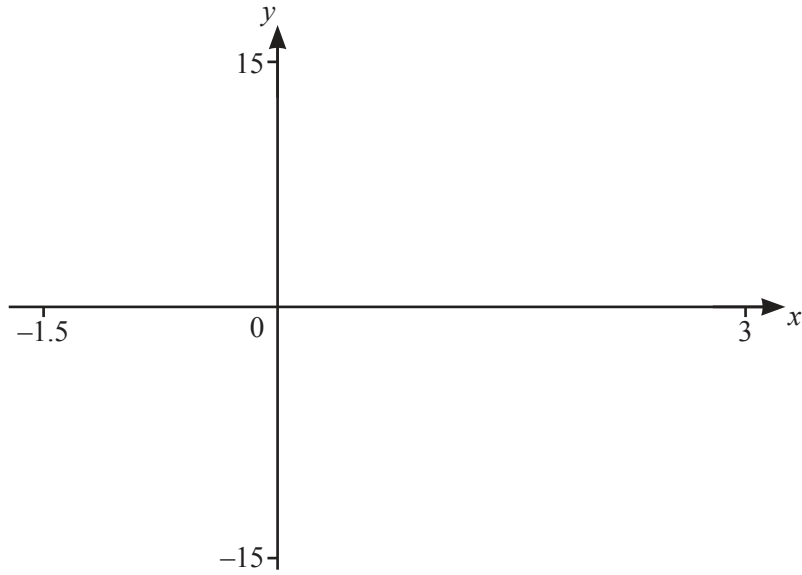

$f(x) = 2x^3 - 5x^2 + 3$  for  $-1.5 \leq x \leq 3$

(a) On the diagram, sketch the graph of  $y = f(x)$ . [2]

(b) Find the zeros of  $f(x)$ .

..... [3]

(c) Find the co-ordinates of the local maximum.

(....., .....) [1]

(d) Find the co-ordinates of the local minimum.

(....., .....) [2]

(e) The equation  $2x^3 - 5x^2 + 3 = k$  has three solutions.

Find the range of values of  $k$ .

..... [2]

4 The table shows the mathematics mark and the physics mark for each of 10 students in an examination.

Mathematics mark ( $m$ )	14	28	38	41	60	66	76	82	90	98
Physics mark ( $p$ )	8	28	66	43	67	56	51	74	85	88

- (a) Complete the scatter diagram.  
The first five points have been plotted for you.

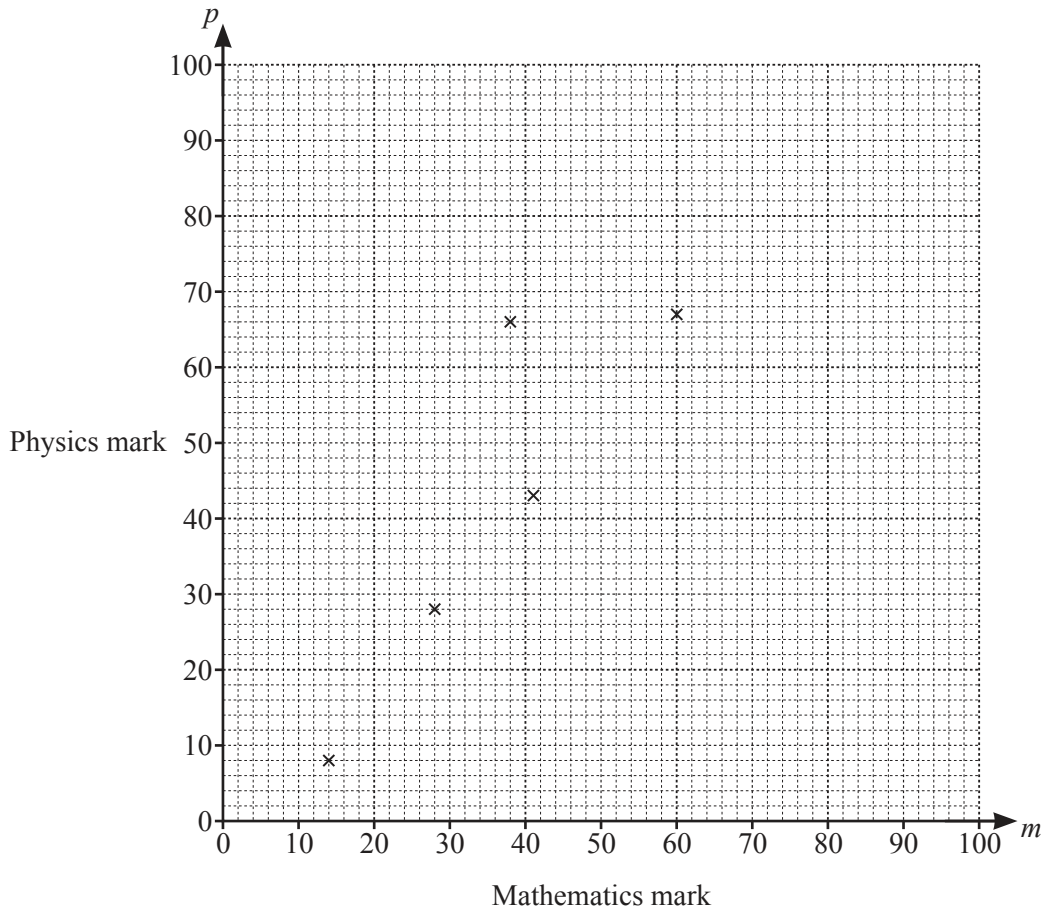

[2]

- (b) Write down the type of correlation shown by the scatter diagram.

..... [1]

- (c) Find the equation of the regression line.  
Write the answer in the form  $p = am + b$ .

$p =$  ..... [2]

- (d) A student was absent for the physics examination but gained 56 marks in the mathematics examination.

Use your answer to **part (c)** to estimate a physics mark for this student.

..... [1]

- (e) The school decided that the physics examination was too difficult and added 5 marks to each of the physics marks.

Write down the new equation of the regression line.

..... [1]

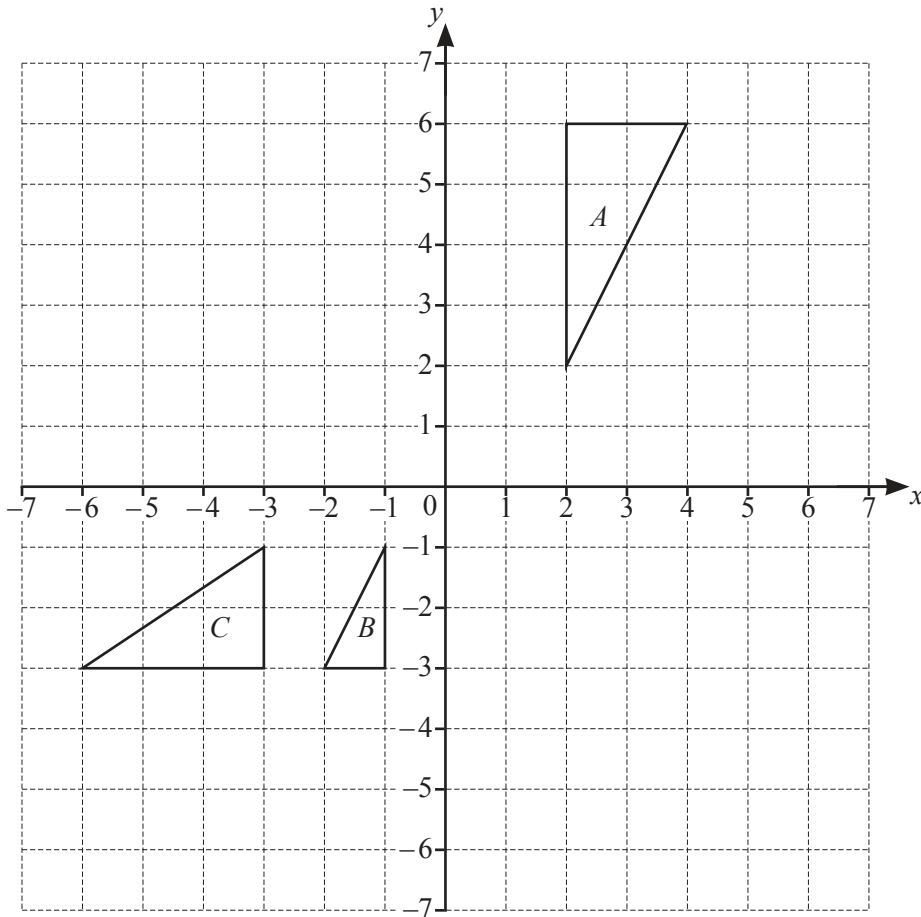

(a) Reflect triangle *A* in the line  $y = 1$ . [2]

(b) Rotate triangle *B* through  $90^\circ$  clockwise about  $(1, 0)$ . [3]

(c) Describe fully the **single** transformation that maps triangle *A* onto triangle *B*.  
 ..... [3]

(d) Describe fully the **single** transformation that maps triangle *B* onto triangle *C*.  
 ..... [3]



- 6 (a)  $P$  is the point  $(3, 5)$  and  $Q$  is the point  $(7, -2)$ .  
 $Q$  is the midpoint of  $PR$ .

Find the co-ordinates of the point  $R$ .

(....., .....) [2]

(b)

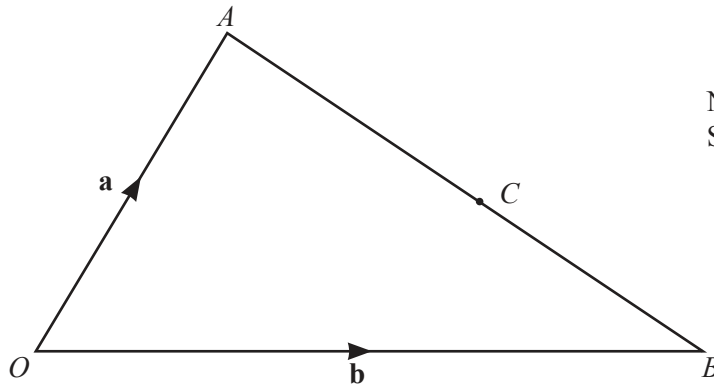

$\vec{OA} = \mathbf{a}$  and  $\vec{OB} = \mathbf{b}$ .  
 $C$  divides  $AB$  in the ratio  $4 : 3$ .

Find these vectors, in terms of  $\mathbf{a}$  and  $\mathbf{b}$ , in their simplest form.

- (i)  $\vec{AB}$

$\vec{AB} = \dots\dots\dots$  [1]

- (ii)  $\vec{OC}$

$\vec{OC} = \dots\dots\dots$  [3]

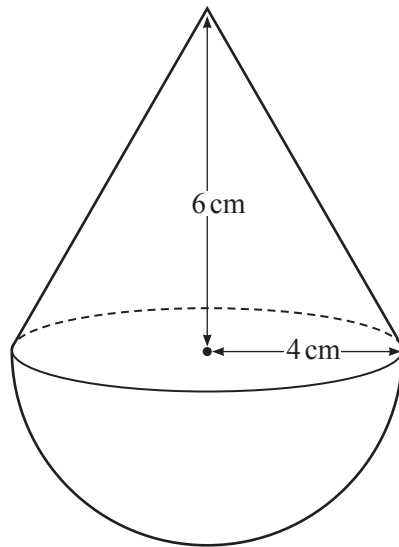

NOT TO SCALE

The diagram shows a child's toy made of a cone joined to a hemisphere. The cone and the hemisphere each have a radius of 4 cm. The perpendicular height of the cone is 6 cm.

(a) (i) Find the volume of the hemisphere.

.....cm<sup>3</sup> [2]

(ii) Find the volume of the cone.

.....cm<sup>3</sup> [2]

(iii) Each cubic centimetre of the hemisphere has a mass of 7.85 g. Each cubic centimetre of the cone has a mass of 0.65 g.

Find the total mass of the toy.

..... g [2]

(b) Find the total surface area of the toy.

.....cm<sup>2</sup> [5]

(c) The height of the cone on a similar toy is 9 cm.

Find the total surface area of this toy.

.....cm<sup>2</sup> [2]

- 8 A dance club has 90 members.  
Here is some information about types of dancing members like.

50 like Ballroom ( $B$ )  
 37 like Latin ( $L$ )  
 47 like Modern ( $M$ )  
 18 like Ballroom and Latin  
 15 like Ballroom and Modern  
 22 like Latin and Modern  
 8 like Ballroom, Latin and Modern

- (a) Complete the Venn diagram.

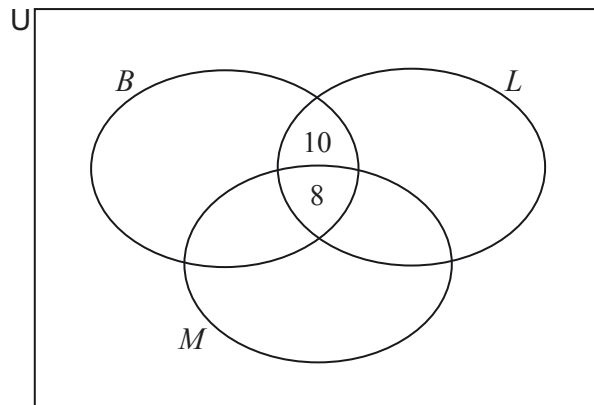

[2]

- (b) Write down the number of members who do not like any of these three types of dancing.

..... [1]

- (c) Two of the 90 members are chosen at random.

Find the probability that they both like Ballroom and Latin but not Modern.

..... [2]

(d) Two of the members who like Ballroom are chosen.

Find the probability that one of these members likes Latin but not Modern and the other likes Modern but not Latin.

..... [3]

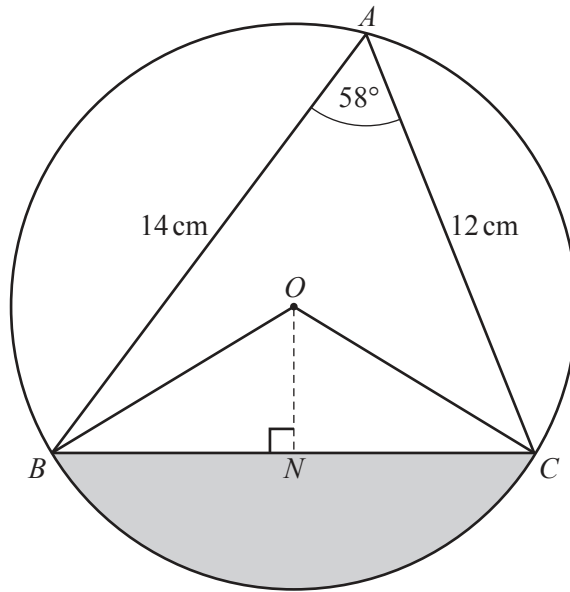

NOT TO SCALE

$A, B$  and  $C$  are points on the circle, centre  $O$ .  
 $ON$  is perpendicular to  $BC$ .  
 $AB = 14$  cm,  $AC = 12$  cm and angle  $BAC = 58^\circ$ .

(a) Show that  $BC = 12.73$  cm, correct to 2 decimal places.

[3]

(b) Explain why angle  $BON = 58^\circ$ .

.....

..... [1]

(c) Calculate  $OB$ , the radius of the circle.

$OB = \dots\dots\dots$  cm [3]

(d) Calculate the area of the shaded segment.

.....cm<sup>2</sup> [3]

10 All lengths in this question are in metres and all areas are in square metres.

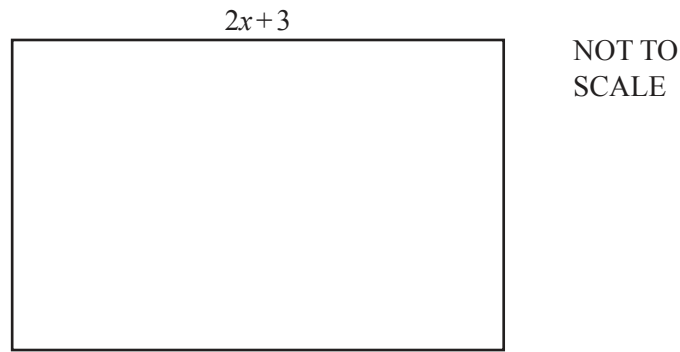

The length of this rectangle is  $(2x + 3)$  and the area is 840.

(a) Write down an expression, in terms of  $x$ , for the width of the rectangle.

..... [1]

(b) The perimeter of the rectangle is 118.

Show that  $2x^2 - 53x + 336 = 0$ .

[3]

(c) Solve the equation  $2x^2 - 53x + 336 = 0$ .  
Show all your working.

$x = \dots\dots\dots$  or  $\dots\dots\dots$  [3]



(d) Find the length and the width of the rectangle.

Length = ..... m

Width = ..... m [2]

11 (a) Simplify.

(i)  $\frac{a^5 \times a^4}{a^3}$

..... [2]

(ii)  $\log_5(5^x)$

..... [1]

(iii)  $\log_9(3^x)$

..... [1]

(b) Solve.

$$3 \log 10 - 2 \log 5 = \log x$$

$x =$  ..... [2]

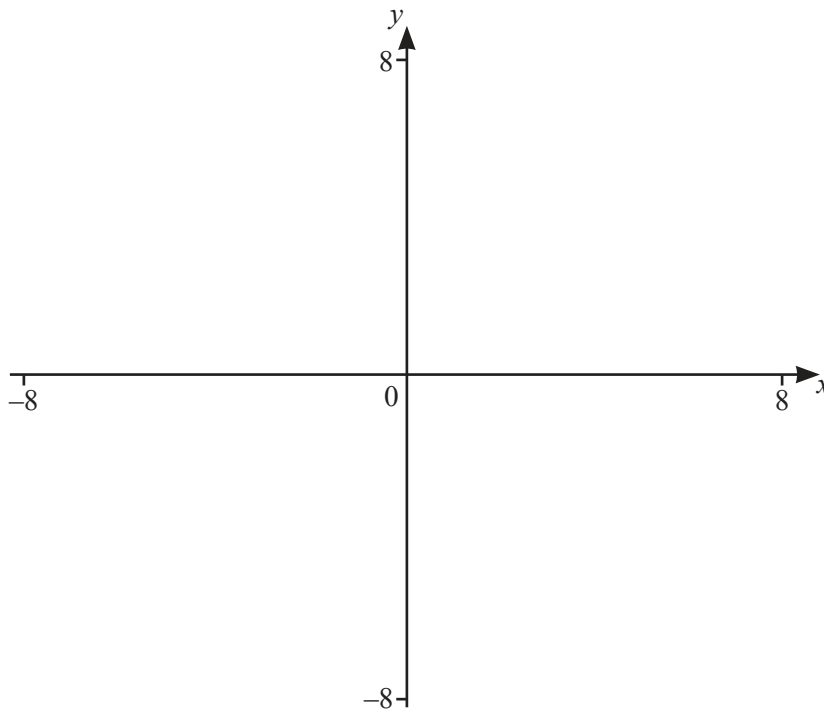

$$f(x) = \frac{3x+2}{(x+2)(x-3)}$$

(a) On the diagram, sketch the graph of  $y = f(x)$  for values of  $x$  between  $-8$  and  $8$ . [3]

(b) Write down the equations of the asymptotes.

....., ....., ..... [3]

(c)  $g(x) = x - 2$

(i) On the diagram, sketch the graph of  $y = g(x)$  for  $-6 \leq x \leq 8$ . [1]

(ii) Solve  $f(x) = g(x)$ .

$x = \dots$  or  $x = \dots$  or  $x = \dots$  [3]

(iii) Solve  $f(x) > g(x)$ .

..... [3]

Question 13 is printed on the next page.

13  $f(x) = 2x + 5$                        $g(x) = 1 - 2x$

(a) Find  $g(-4)$ .

..... [1]

(b) Find  $f^{-1}(-7)$ .

..... [2]

(c) Find  $g(f(3))$ .

..... [2]

(d) Find and simplify  $f(g(x))$ .

..... [2]

(e) Find and simplify  $g^{-1}(x)$ .

$g^{-1}(x) =$  ..... [2]

(f) Write as a single fraction, simplifying your answer.

$$2 + \frac{3}{f(x)}$$

..... [2]

Permission to reproduce items where third-party owned material protected by copyright is included has been sought and cleared where possible. Every reasonable effort has been made by the publisher (UCLES) to trace copyright holders, but if any items requiring clearance have unwittingly been included, the publisher will be pleased to make amends at the earliest possible opportunity.

To avoid the issue of disclosure of answer-related information to candidates, all copyright acknowledgements are reproduced online in the Cambridge Assessment International Education Copyright Acknowledgements Booklet. This is produced for each series of examinations and is freely available to download at [www.cambridgeinternational.org](http://www.cambridgeinternational.org) after the live examination series.

Cambridge Assessment International Education is part of the Cambridge Assessment Group. Cambridge Assessment is the brand name of the University of Cambridge Local Examinations Syndicate (UCLES), which itself is a department of the University of Cambridge.